



Description

Digital alarm unit ALU-AP has the following characteristics:

1. 10 digital inputs
2. Operates in **MASTER** or **SLAVE** mode.
3. It can connect with other devices through a RS485 network with two ways: either as an independent network where there is one device set in MASTER mode and all the rest are in SLAVE mode or as a PC network where a PC has full control of the network and all the devices are set in SLAVE mode. Each device's address is adjusted from parameter N.70 **AdF**. The network needs to be powered with +12÷24VDC.
4. Capability of **controlling the fault line** for every input through parameters **L1÷L10** and **i1÷i10**, see sketches 3, 4. **Line control must be applied only with +24VDC power supply.**
5. Without fault line control: NO or NC contact with common at 0V or +24V for adjusting each input independently, see sketch 2.
6. Internal relay with one associated auxiliary contact 250VAC 10A for setting up an external alarm circuit in case of **main power failure.**
7. The device can be placed on the **ship's bridge.**
8. The device can connect to a **thermal printer** for instant print of any alarm (applied only in network mode).
9. One general internal relay output 250VAC 10A for siren activation.
10. 14 digital outputs for driving relays where input alarms, fault line alarms and LED operation for monitoring can be driven into groups or separately. Maximum total load of outputs is 300mA.
11. Capability of **holding the alarm** in every input after RESET through parameters **H1÷H10.**
12. **Time delay** for each input can be set from 0÷100 sec.
13. Accepts alarm inputs of ±24VAC/DC.
14. Up to 98 devices can connect to a network with common RESET, TEST LAMP and alarm activation.
15. One or more devices connected to a network can become a **repeater** of any other device. This means that the alarms of the latter device will be forwarded to the repeater device.
16. Capability of adjusting contact 9 in TEST LAMP operation and contact 10 in RESET operation for usage of **remote buttons.**
17. Adjustment of **LED brightness** by pressing SET button.
18. Power supply: 24VAC ± 10% 50/60 Hz ή 24VDC +30% / -10%
19. Maximum consumption: 10W
20. Internal power supply fast blow fuse: 1A
21. Internal fast blow fuse in the outputs: 315mA
22. Internal fast blow fuse in the network's communication: 315mA

Operation of the device in a network

The device accepts a signal through an input and the corresponding LED starts flashing while the relay (siren) of the device is activated. If the **RESET** button is pressed, the LED stops flashing and remains ON until the signal that caused the alarm is removed from the input. By pressing the **TEST** button, all LEDs light up simultaneously in order to verify good operation of the device.

In MASTER mode the device displays "nnA", while in SLAVE mode it displays its address on the network **A 0, A 1**, etc. The **RESET** and the **TEST** buttons are common for all devices within a network. This means that they operate at the same time in all connected devices.

ALARM

Alarm inputs can be driven towards one output either separately or into groups.

Address alarm of the MASTER device: when several devices operate in a MASTER - SLAVE network and the MASTER device does not receive any data from one or more SLAVE devices, the indication **A 1, A 2 ...** starts flashing, which corresponds to the address of the SLAVE device that isn't sending any data to the MASTER device. This causes the activation of the output set from the parameter No.33 **AdF**.

Fault line alarm in MASTER and SLAVE device: the indication **L 1, L 2 ...** starts flashing, indicating the channel that is faulty while the corresponding programmable output defined by the parameter No.32 **brL** is activated.



Repeater alarm: when a repeater loses the connection with the mother device, the indication **rEP** starts flashing.

The **cut line alarms** and the **lost-communication alarms** in a SLAVE device can be driven either into separate outputs either into the same output defined by the parameters No.32 **brL** and No.33 **AdF**.

Power failure setup



An internal relay 250VAC 10A with one contact (terminal blocks 11, 12) is available to set up an external alarm circuit in case main power supply fails. When the device is powered on, the said auxiliary contact will open and when power failure occurs the same contact will close, therefore an external alarm circuit with a separate power supply will also close and consequently, an audible and/or visual alarm will be triggered.

Button's function

button	function
ENTER	- enter parameter's menu - confirm a new value of a parameter
SET	cancel a new value of a parameter
	- change parameter within the parameter menu - alarm RESET button outside the parameter menu
	- change parameter within the parameter menu - TEST LAMP button outside the parameter menu

Managing the parameters

By pressing [ENTER] we enter the parameters menu and the first parameter is displayed, **Cod**. By pressing [SET] the value of the parameter is displayed and we set number **Cod = 22**.

By pressing [ENTER] we confirm the new value and with the [], [] we scroll between the parameters.

By pressing [SET] we cancel the new value and we return to the parameter's name.

By pressing [ENTER] again we exit the parameter menu.

Connection diagram

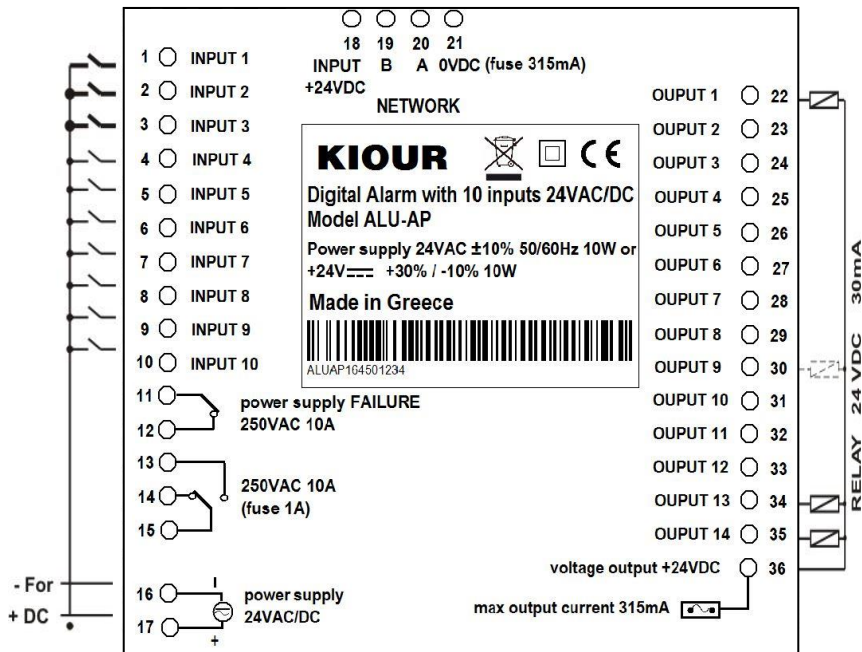

Connection diagram in a network (up to 98 devices)

Every 50 devices a network amplifier RS485 Type **KIOUR RS485 Amplifier** must interfere.

Sketch 1

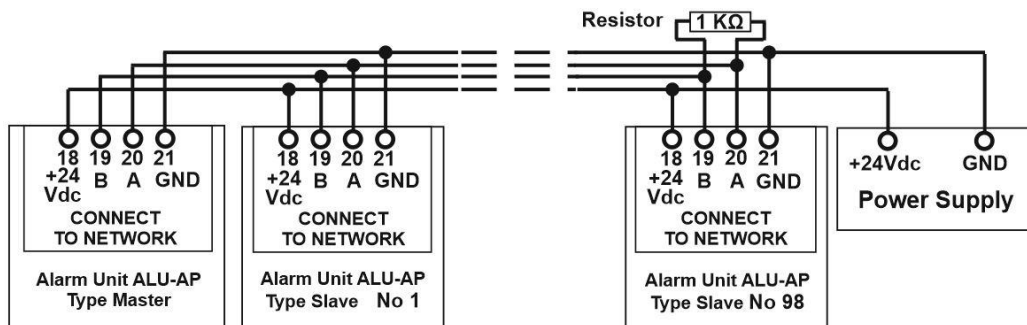

Parameter's table

No	Parameter's description	min	max	def	UOM
1	Cod Entry code in parameter menu = "22"	0	250	0	
2	t 1 Time delay of alarm 1 in input 1	0	100	0	sec
...
11	t10 Time delay of alarm 10 in input 10	0	100	0	sec
12	o 1 The alarm of the 1 st input can be driven into one of the 14 outputs. For o 1 = 0 , the alarm is not driven into any output.	0	14	0	
...	
21	o10 The alarm of the 10 th input can be driven into one of the 14 outputs. For o10 = 0 , the alarm is not driven into any output.	0	14	0	
22	d 1 The 1 st LED can be driven into one of the 14 outputs. For d 1 = 0 , the LED is not driven into any output	0	14	0	
...	
31	d10 The 10 th LED can be driven into one of the 14 outputs. For d10 = 0 , the LED is not driven into any output	0	14	0	
32	brL The fault line alarm can be driven into one of the 14 outputs	0	14	0	
33	AdF The lost communication alarm can be driven into one of the 14 outputs	0	14	0	
34	Operation of input with NO or NC contact. With line control: i1 = 0 or 1 → NO and i1 = 2 or 3 → NC. Further details in sketches 3 and 4. Without line control: 1. If the contact is tied to +24V: i1 = 0 → NO i1 = 1 → NC 2. If the contact is tied to 0V: i1 = 2 → NO i1 = 3 → NC Further details in sketch 2.	0	3	0	
35	
43	Operation of input with NO or NC contact. With line control: i10 = 0 or 1 → NO and i10 = 2 or 3 → NC. Further details in sketches 3 and 4. Without line control: 1. If the contact is tied to +24V: i10 = 0 → NO i10 = 1 → NC 2. If the contact is tied to 0V: i10 = 2 → NO i10 = 3 → NC Further details in sketch 2.	0	3	0	
44	H 1 For H 1 = 1 , if the input alarm persists, so does the output alarm (1÷14) after the RESET For H 1 = 0 , the output alarm (1÷14) disappears after the RESET	0	1	0	
...	
53	H10 For H10 = 1 , if the input alarm persists, so does the output alarm (1÷14) after the RESET For H10 = 0 , the output alarm (1÷14) disappears after the RESET	0	1	0	
54	L 1 Activation of line control, where for L 1 = 0 , there is no line control while for L 1 = 1 there is line control. For further details see sketches 3 and 4.	0	1	0	
...	...				
63	L10 Activation of line control, where for L10 = 0 , there is no line control while for L10 = 1 there is line control. For further details see sketches 3 and 4.	0	1	0	
64	rEt For rEt = 0 , the RESET and TEST LAMP are activated on the network, while for rEt = 1 , the RESET and TEST LAMP are deactivated.	0	1	1	
65	diS For diS = 1 , "nna" is displayed where for diS = 0 , only a dot is displayed.	0	1	1	
66	tE Input 9 configuration for TEST LAMP mode, where tE = 0 is for normal mode and tE = 1 is for TEST LAMP mode.	0	1	0	
67	rE Input 10 configuration for RESET mode, where rE = 0 is for normal mode and rE = 1 is for RESET mode.	0	1	0	
68	If rEP = 0 , the device is not a repeater of any of the devices If rEP = 1÷98 , the device is repeater of the device with the corresponding address If rEP = 99 , the device is a repeater of the network's MASTER device. The MASTER device cannot become a repeater of any device in the network. At the repeater, the RESET and TEST LAMP of the inputs are deactivated, whereas the time delays that are applied to the inputs are the mother's device.	0	99	0	
69	tYP MASTER or SLAVE mode, where tYP = 20 is for MASTER mode and tYP = 21 is for SLAVE mode	20	21	20	
70	Add 1. Devices network: A device is programmed in MASTER mode and at its Add parameter we enter the number of the SLAVE devices (1÷98). In the respective parameter (Add) in the SLAVE devices we enter its unique network address (1÷98). For connecting the devices in a network see sketch 1. 2. PC – device network: all devices are in SLAVE mode and the Add parameter has the device's unique network address (1÷98).	0	98	0	

Input configuration according to the parameters L1, L2 ... L10 and i1, i2 ... i10

- Without line control where line parameters L1, L2 ... = 0.

Sketch 2

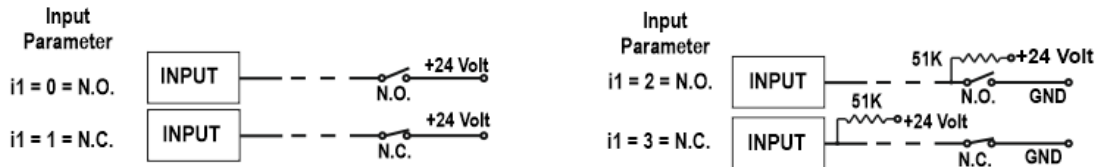

- With line control where line parameters L1, L2 ... = 1.
ATTENTION: Line control must be applied only with +24VDC power supply.

1st case: N.O. contact (normally open)

Sketch 3

Parameter LINE : L1 = 1
Parameter Input : i1 = 0 or 1 = N.O.

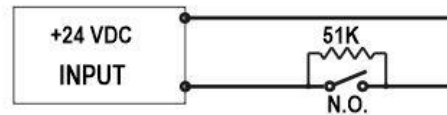

Line fault occurs when there is:

- a cut line or a short circuit at 0 Volt, where a line alarm is ON
- a short circuit at +24VDC, where an alarm is ON but not a line alarm

2nd case: N.C. contact (normally close)

Sketch 4

Parameter LINE : L1 = 1
Parameter Input : i1 = 2 or 3 = N.C.

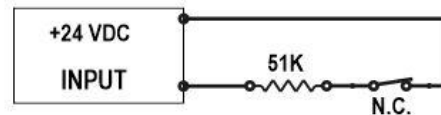

Line fault occurs when there is:

- a cut line or a short circuit at 0V, where an alarm is ON but not a line alarm
- a short circuit at +24VDC, where a line alarm is ON

Technical specifications

Power supply: 24VAC \pm 10% 50/60Hz or 24VDC +30% / -10%

Maximum consumption: 10W

Internal power supply fast blow fuse: 1A

Internal fast blow fuse in the outputs: 315mA

Internal fast blow fuse in the network's communication: 315mA

General internal alarm relay 250VAC 10A resistive loads

Internal relay with one associated auxiliary contact 250VAC 10A for setting up an external alarm circuit in case main power supply fails

The device can be placed on the ship's bridge.

The device can connect to a thermal printer for instant print of any alarm (applied only in network mode).

Operating temperature: -15 \div +70°C

Storage temperature: -20 \div +80°C

The device is mounted on a panel hole with dimensions 137x137mm

Connection with plug in terminal blocks

IP protection rating: IP42 front side. To be installed in an enclosure which provides protection against solid foreign objects and liquids at least IP 42.

Class of equipment: Class II

Internal audible alarm is not included (buzzer)

Dimensions

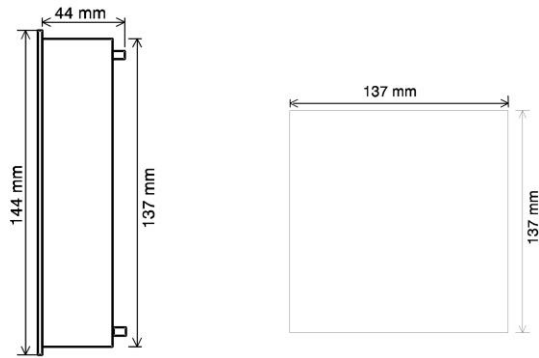
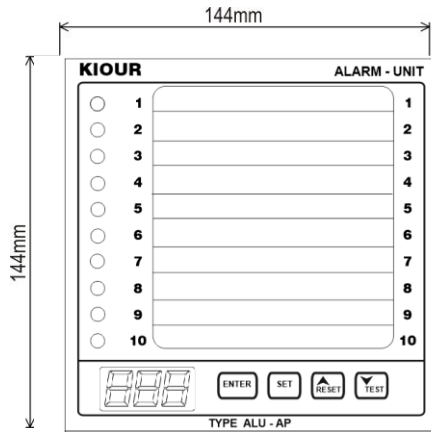

Internal fuses

Internal power supply fast blow fuse: 1A
 Internal fast blow fuse in the outputs: 315mA
 Internal fast blow fuse in the network's communication: 315mA

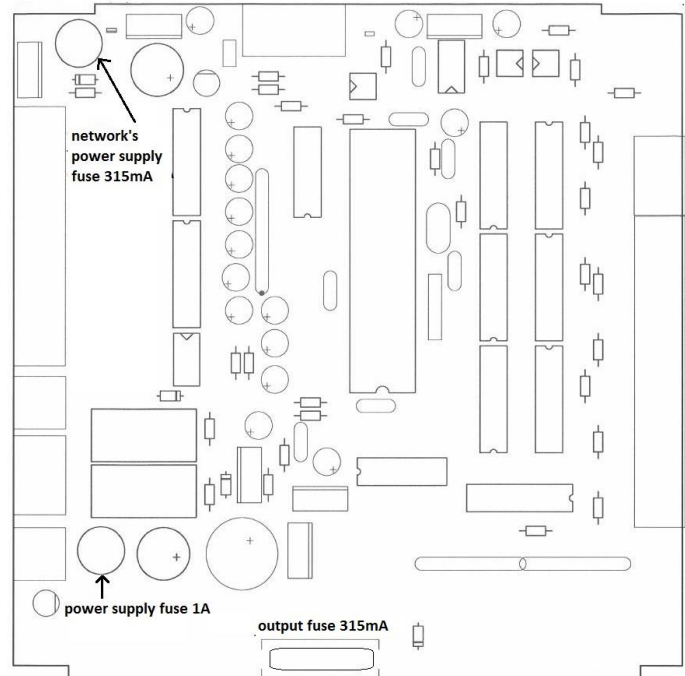

Made in Greece.



ATTENTION according to safety standards, the device must be properly positioned and protected from any contact with electrical parts. All parts that provide protection must be fastened in such a way that they cannot be removed without the use of tools. **ATTENTION:** disconnect the power supply of the device before proceeding to any kind of maintenance. **ATTENTION:** do not place the device near heat sources, equipment containing strong magnets, in areas affected by direct sunlight or rain. **ATTENTION:** prevent electrostatic discharges at the side slots of the device and sharp objects from being inserted. **ATTENTION:** separate the signal's cables from the power supply's cables to prevent electromagnetic disorders. Signal cables must never be in the same pipe with the power supply cables. **Use the device only as described in this document, not to use itself as a security device. The device must be disposed of in accordance with local standards for the collection of electrical and electronic equipment. Read and keep these instructions.** The device is under two year's guarantee of good operation. The guarantee is valid only if the manual instructions have been applied. The control and service of the device must be done by an authorized technician. The guarantee covers only the replacement or the service of the device.

KIOUR preserves the right to adjust its products without further notice.

